

STATCOM for Dynamic Performance Optimization of Grid Connected Wind Power System

Ahmed Abdelmalek AbdelHafez¹ Jaber Ibrehaim AL-Sadey¹ Radwan Taha Al-Bouthigy¹
¹Electrical Engineering Department, Faculty of Engineering, Assiut University, Assiut, Egypt,
PO.715164, elhafez@aun.edu.eg

Abstract— Large disturbances in an induction generator-based wind system necessitate rapid compensation for the reactive power. This article addresses the application of Static Synchronous Compensator (STATCOM) in optimizing the performance of grid connected wind power system. The functionality of the static synchronous compensator in maintaining system stability and reliability during/post diverse severe disturbances is thoroughly investigated. A design procedure for STATCOM, particularly the capacitor in the DC side was advised.

Index Terms— Self-Excited Induction Generator, Wind Farm, STATCOM, Disturbances, Island Mode.

I. INTRODUCTION

Recently, the Wind Farms (WFs) represent integral electrical power supplier in many utilities, particularly for remote area customers. For large utility-scaled wind sources incorporating WFs with (100-300MW) range, a large number of wind turbines are clustered into an area. With such spread of wind-generated electricity, it is primitive to address stability, reliability and security of wind power conversion during the disturbance and its interaction with the utility. Earlier, the disconnection of the wind power plant during disturbances facing the power grid was a common operating regime. However, this is no longer acceptable option, as it may results in grid instability [1].

A WF could be composed of several channels of wind turbine-generator set operating together. Induction generators usually are the most common generator option in a wind power system, due to their simplicity, ruggedness and

maintenance free construction [2]. Commonly, induction generators are directly attached to the grid. To maintain the air gap flux, the inductor generator has to be supplied by the reactive power. The flow of reactive power particularly for the machines in a cluster, affects the voltage magnitude at different system buses. Moreover, the disturbances as sudden load injection and or losing turbine-generator set(s), aggravate the flow of the reactive power and hence the drop in the voltage. If the system/grid is unable to satisfy the reactive power requirements for induction generators and the load; this may result in tripping of the wind turbines and grid instability [2-4].

Series of Flexible AC Transmission Systems (FACTS) were developed recently using power electronics in order to control power flow, improve transient stability, inject/absorb reactive power and regulate the voltage profile. STATCOM is a shunt device of the FACTS family, thus it enjoys reduced

volumetric dimension and rating. Moreover, STATCOM has fast dynamic response, as it could be considered as a current controlled device.

STATCOM could instantaneously deliver a reasonable reactive power and hence maintain the voltage profile in the system within the allowed range. Commonly, this is realized by controlling the magnitude of the STATCOM generated voltage and hence the flow of reactive power. The controlling of the voltage magnitude is performed by means of a Voltage Source Converter (VSC) connected to the secondary side of a coupling transformer. The VSC uses forced-commutated power electronic devices as GTOs, IGBTs or IGCTs to synthesize a sinusoidal waveform from a DC voltage [5-17]. Normally, a large capacitor on the DC side of VSC is deployed for maintaining the DC voltage constant.

Basically, the STATCOM is controlled through two loops. The first is for regulating the AC voltage magnitude and hence controlling the direction/value of the reactive power. The other is for regulating the DC voltage across the capacitor, through which the active power flow is controlled [7-15].

A significant research effort was drafted into design and analysis of the STATCOM operation in power system [7,8,11,12,13]. However, the focus was on the tuning of the STATCOM controllers. Dimensioning the STATCOM components, particularly DC link capacitor was slightly investigated. Moreover, operation of the STATCOM in vulnerable grids, as induction generator-based wind system has not received such interests.

This article investigates the impact of incorporating STATCOM in grid connected wind farm regarding steady-state and dynamic performances. A design procedure for a STATCOM is

proposed. The focus is on the DC side capacitor, which allows reactive power injections. An analytical expression is derived for dimensioning the capacitor. A d-q controller for STATCOM is utilized. This controller regulates the DC-link voltage and the AC side voltage magnitude. To assess the robustness and reliability of the STATCOM several severe disturbances are suddenly applied to grid-connected four buses system.

II. SYSTEM LAYOUT

One-line diagram for system under concern is shown in Figure 1. It is grid connected wind power system.

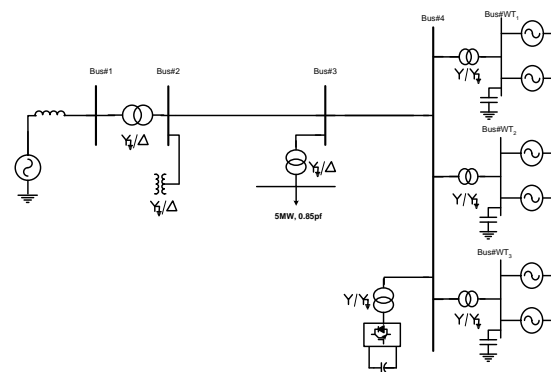

Figure 1. Grid-connected Wind farms system

The system is composed of four buses as shown in Figure 1. The grid is coupled to Bus#1; it is modeled by 120kV and 2500MVA. 5MW load is attached to Bus#3. The WF cluster and the STATCOM are connected to Bus#4. The parameters of the system are given in Table1. The WF consists of three wind plants; each plant contains two parallel connected wind turbine generator sets. The wind plant delivers 2x1.5MW at 600V. Part of the reactive consumed by the induction generator is supplied locally by 400kVAR capacitor bank each, installed at the machine terminals. The parameters of the system shown in Figure 1 are given in Table 1.

TABLE I. PARAMTERS OF SYSTEM UNDER CONCERN

Component	Bus	Bus	Parameters
Transformer	1	2	120/25kV, 47MVA, Rm=Lm=500pu, R1=R2=0.0027pu, L1=L2=0.08pu
Transformer	4	WTi	25kV/600V, 4MVA, Rm=500pu, Lm=2500pu, R1=R2=8.4x10-4pu, L1=L2=0.025pu
Transmission line	2	3	25km
Transmission line	3	4	10km
Transmission line	4	WTi	5km
Generator	-	WTi	1.56MW, 0.9pf, 600V, Rs= 0.0048pu, Lls= 0.1248pu, R _r '=0.0044pu, L _{lr} '=0.1791pu, Lm=6.77pu

A. Wind Turbine (WT)

Wind turbines, in the system under concern, are coupled to the rotor of the self-excited squirrel cage induction generator. The stator is directly connected to the grid. A part of the machine excitation is supplied locally through capacitor bank at the generator terminals. The wind turbine is modeled based on the steady-state power characteristics of the turbine. The stiffness of the drive train is assumed infinite. The turbine output power is given by,

$$P_m = \frac{\pi}{8} C_p \rho D^2 v_\omega^3 \quad (1)$$

where P_m , v_ω , ρ , D and C_p are the turbine output power, wind speed, air density, blade diameter and performance coefficient of the turbine respectively. C_p is a function in the pitch angle, β , and tip speed ratio of the rotor blade tip speed to wind speed, λ , as given by,

$$C_p(\lambda, \beta) = C_1 \left(\frac{C_2}{\lambda_1} - C_3 \beta - C_4 \right) e^{-\frac{C_5}{\lambda_1}} + C_6 \lambda \quad (2)$$

where coefficients C_1 , C_2 , C_3 , C_4 , C_5 , and C_6 are respectively, 0.5176, 116, 0.4, 5, 21 and 0.0068. λ_1 is given by,

$$\frac{1}{\lambda_1} = \frac{1}{\lambda + 0.08\beta} - \frac{0.035}{\beta^3 + 1} \quad (3)$$

The characteristics of the turbines in the system under concern are shown in Figure 2.

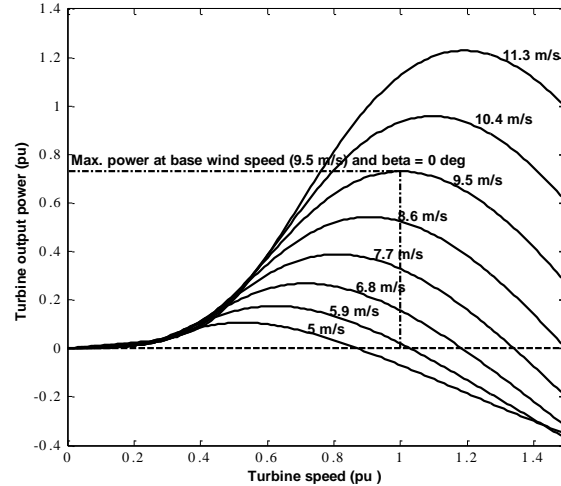

Figure 2. Turbine output power as a function in rotor speed at different wind speed

The turbine output power is wind and rotor speeds dependent. The base wind speed considered in this work is 9.5m/s, as this represents the local average wind speed in Egypt [18].

In Figure 2, the pitch angle β is set to zero, as this maximizes the turbine output power. However, for high wind speed, the pitch angle is controlled to limit the generator output to the nominal value.

B. Self-Excited Induction Generator

The self-excited squirrel cage induction generator is modeled in a synchronous rotating frame [19]. The models of the wind turbine and self-excited induction generator are adequately reported in the literature [20-22].

III. STATCOM DESIGN

The principles and fundamentals of the STATCOM are adequately highlighted in the literature[5-17]. However, for the purpose of illustration, the basic principle

10-15sec, the power supplied to the grid reduces by the amount drawn by the load. This decrease continues post losing of the generation plant.

For the operation without Statcom, the power flows to the grid before tripping of the generators. Then, the grid supplies the load at Bus#3, until the grid was disconnected.

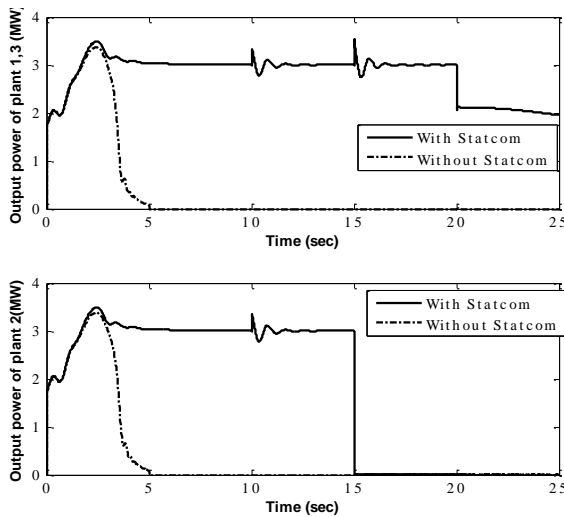

Figure 5. Output powers of plant 1,3 (top) and plant 2(bottom) with STATCOM (solid), without STATCOM(dotted) for injection of 5MW, 85pf load at Bus#3 at 10sec, tripping of plant 2 at 15sec, island mode at 20sec

Losing wind plant has no impact on the remaining plants regarding the steady-state power balance for the operation with STATCOM, Figure 5. However, this scenario changes for the operation without STATCOM, as losing a generator set results in immediately tripping of other generation plants. Figure 5 shows that the three wind plants trips at 5sec in case of operation without STATCOM.

In the island mode, as shown in Figure 5, the healthy wind plants reduce their output to achieve power balance. However, due to the mismatches between the turbine output and the captured wind energy, the turbine speed increases up to the level; which probably activate turbine

protection. It was found that application of energy storage elements, as flywheel, to absorb the surplus wind energy during this scenario restores the turbine speed to the allowable range.

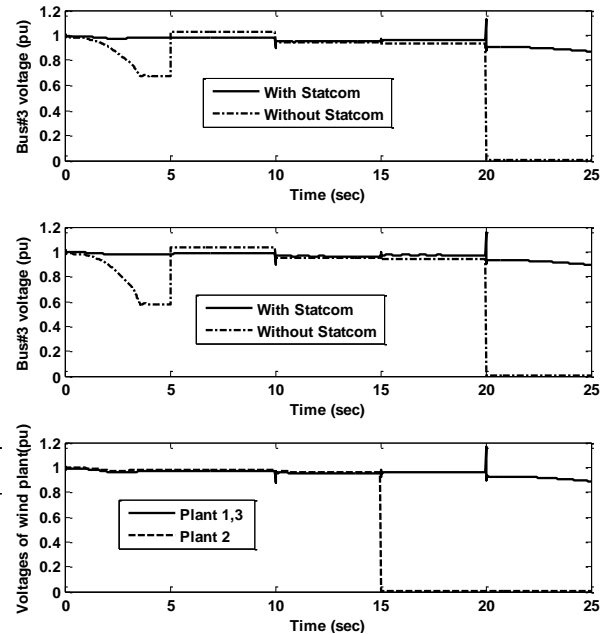

Figure 6. Voltage at Bus#3 (top), with STATCOM(solid), without STATCOM(dashed); Voltage at Bus#4 (middle), with STATCOM(solid), without STATCOM(dashed); Voltage at wind power plants (bottom), plant 1, 3 (solid), plant 2 (dotted) for injection of 5MW, 85pf load at Bus#3 at 10sec, tripping of plant 2 at 15sec, island mode at 20sec

The voltages at Buses 1-4 experience four distinct features in the simulated time span for the operation without Statcom, Figure 6. In the period 0-5sec, the voltage drops. This returns to the transient of starting of the induction generator and their reactive power requirements. In the period 5-10sec, the voltage experiences an increase. This is attributed to the fact that all generator are off; however, their self-excitation arrangements (3x400kvar) are still attached to the system. The sudden injection of the load at Bus#3 results in slightly reduction in the voltages during 10-20sec. The voltage ceases to zero

during island mode for the operation without STATCOM.

For the system operation with STATCOM, the voltage at all buses almost remains constant during sudden load injection and disconnection of wind plant, in the period from 0-20sec. However, the voltage of the different buses reduces during and post grid disconnection, the period 20-25sec. This attributes to imbalance between the reactive power demand and generation. The induction generators, the load at Bus#3 and the transmission lines consumed more reactive power than that generated by STATCOM and capacitor banks at the terminals of the remaining wind power plant.

Figure 6 shows that the voltage at Bus#4, where STATCOM is located, is higher than load bus, Bus#3, and at the terminals of the generators. This indicates the flow of the reactive power from STATCOM to supply the requirements of the induction generators and to partially fulfill load reactive power requirement. The remaining of load reactive power demand is supplied from the grid.

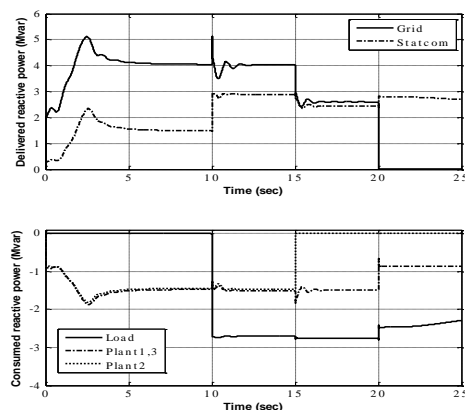

Figure 7. Generated reactive powers (top) from Grid (solid) and STATCOM(dashed); Consumed reactive powers (bottom) at load (solid), plant 1,3 (semi-dashed) and plant 2 (dashed) for injection of 5MW , 85pf load at Bus#3 at 10sec, tripping of plant 2 at 15sec, island mode at 20sec

In producing Figure 7, the reactive power generated by capacitor banks at terminals of the generator is ignored. This power is nearly equal to (3x400kvar) in the period from 0-15sec, where all plants are operating. However, it drops to (2x400kvar) after disabling plant#2 and its associated self-excitation arrangements. Also, the reactive power consumed by transmission lines is not included in the above figure. As, the bulk flow of the reactive power was the only considered.

In the period 0-10sec, before load injection at Bus#3, the reactive power generated from STATCOM, fixed excitation facilities and delivered from the grid fulfill the induction generator and transmission line requirements. The generators consumed nearly 4.7Mvar, while the delivered reactive power is around 5.9Mvar. The 1.2Mvar difference improves the regulation at different buses, as it fulfills the reactive power requirements of the transmission lines and transformers.

During/post load application, period from 10-15sec, the STATCOM increases the power generated nearly by 100%. This is to share in fulfilling load reactive power demand. The difference between the generated reactive power and that consumed by the generators and load drops by around 34%. Thus the voltage during this period is lower than that prior load injection.

As wind plant#2 is tripped, the generated STATCOM reactive power drafts from the tripped generator to the load; and the STATCOM share more in load reactive power demand. Thus the reactive power imported from the grid as shown in Figure7, is reduced.

Figure 7, shows that during grid disconnection, the STATCOM has to satisfy reactive power requirements of the load, induction generators and

transmission lines. These demands exceed the capacity of the STATCOM; which worsens voltage regulation to unacceptable levels. The system in the island mode requires injection of more reactive power to avoid voltage instability.

V. CONCLUSION

The operation of 3Mvar STATCOM in a grid-connected wind power system is thoroughly investigated in terms of dynamic and transient performances. Diverse operating scenarios were addressed as sudden injection of 5MW load, losing one plant of 3MW capacity, and operating in island mode. The following conclusions could be extracted:

- Dynamic reactive power compensation devices as STATCOM are integral element in any wind based-asynchronous generator system. As, self-excitation facilities fulfill the reactive power requirement of the generator during static conditions. However, the transient and dynamic states mandate the application of these fast acting compensators.
- To maintain system operation during/post grid failure case, energy storage arrangements have to be employed for absorbing the difference between the captured wind power and the load. Also, to maintain the voltage within acceptable range, the reactive power needs to be supplied to the system.

REFERENCES

- [1] Y. K. Chauhan, S. K. Jain and B. Singh, Maejo, “Performance of self-excited induction generator with cost-effective static compensator”, *International Journal of Science and Technology*, Maejo Int. J. Sci. Technol. Vol. 6(01), pp.12-27, 2012.
- [2] R. C. Bansal, T. S. Bhatti, and D. P. Kothari, “A bibliographical survey on induction generators for application of nonconventional energy systems”, *IEEE Trans. Energy Convers.*, vol. 18, no. 3, pp. 433–439, Sep. 2003.
- [3] B. Perumal Venkatesa and J. K. Chatterjee, “Analysis of a self excited induction generator with STATCOM/battery energy storage system”, *IEEE CNF*, pp. 6, Apr. 2006.
- [4] W. L. Chen, Y. H. Lin, H. ShengGau, and C. HungYu, “STATCOMControls for a Self-Excited Induction Generator Feeding Random Loads”, *IEEE TRANSACTIONS ON POWER DELIVERY*, VOL. 23, NO.4, pp. 2207-2215, OCT. 2008.
- [5] N. Mithulananthan, C. A. Canizares, J. Reeve ; and G. J. Rogers, "Comparison of PSS, SVC, and STATCOMcontrollers for damping power system oscillations" *IEEE Transactions on Power Systems*, Vol. 18, issue 2, pp. 786-792, 2003.
- [6] You Jie Ma, Yi Li, Xue Song Zhou" A Review of Static Synchronous Compensators (STATCOM)" *Applied Mechanics and Materials Journal*, Vol. 270, pp. 1389-1392, 2013.
- [7] K. Jain, K. Joshi, A. Behal, and N. Mohan, “Modeling and Nonlinear Control of STATCOMs for Fast Voltage Regulation”, 2005 American Control Conference. Portland, OR, USA. pp. 1295- 1300, June 8-10, 2005.
- [8] N. Goel, R.N. Patel, S. T. Chacko, “Genetically Tuned STATCOMfor Voltage Control and Reactive Power Compensation”, *International Journal of Computer Theory and Engineering*, Vol. 2, No. 3, pp. 1793-8201, Jun. 2010.

- [9] Pärnu, Estonia, R. Cimbals, O. Krievs, L.Ribickis, “A Static Synchronous Compensator for Reactive Power Compensation under Distorted Mains Voltage Conditions”, 10th International Symposium Topical Problems in the Field of Electrical and Power Engineering, pp .151-155, Jan.10-15, 2011.
- [10] R. Kachroo and H.S. Dalvi,” FACTS Devices Using Neuro Fuzzy Controller in Stabilization of Grid Connected Wind Generator “”, International Journal of Science and Technology, Vol. 4, pp.12-27, 2012.
- [11] GH. Shahgholina, S. Eshehardiha, H. Mahdavi-Nassab and M. R. Yousefi, “ A Novel Approach in Automatic Control Based on the Genetic Algorithm in STATCOMfor Improvement Power System Transient Stability “ 4th International IEEE Conference on Intelligent Systems, 2008, Vol. 4, pp. 14-19, 2008.
- [12] K. K. Pinapartuni and K. Mohan, “ DQ based Control of DSTATCOMfor Power Quality Improvement”, VSRD International Journal of Electrical, Electronics & Communication Engineering, Vol. 2, issue 5, pp. 207-227, 2012.
- [13] S. F. Faisal, A. H. M. Rahim and J. M. Bakhashwain” A Robust STATCOMController for a Multi-Machine Power System Using Particle Swarm Optimization and Loop-Shaping” World Academy of Science, Engineering and Technology, pp. 418-424, 2007.
- [14] P. Giroux, G. Sybille, and H. Le-Huy”Modeling and simulation of a distribution STATCOMusing Simulink's Power System Blockset ” . The 27th Annual Conference of the IEEE Industrial Electronics Society, 2001. IECON '01, Vol. 2, pp. 990-994, 2001.
- [15] PK Dash” A New Real-Time Fast Discrete S-Transform for Cross-Differential Protection of Shunt-Compensated Power Systems ” IEEE Transactions on Power Delivery , Vol. 28, issue 1, pp. 402-410, 2013.
- [16] S. Panda, N. Padhy ” Optimal location and controller design of STATCOMfor power system stability improvement using PSO” Journal of the Franklin Institute, Vol. 345, Issue 2, pp. 166–181, 2008.
- [17] J.B. Lv, S.X. Wang ”Comparative Research on Power Quality Control Technology in Distribution System” Advanced Materials Research Journal, Vol. 10, pp. 245-252, 2013.
- [18] R. Ali, A. A. AbdElhafez and G. El Sade” Wind energy: Past, Present and Future ” The 8th International Conference on Electrical Engineering 2012, ICEENG-8, 2012, pp. 35-39, 29-31 May, 2012.
- [19] P. C. Kruae, O. Wasyncuk, and S. D. Sudhoff” Analysis of Electric Machinery” 2nd IEEE press, 2002.
- [20] A.H. Noorazi and A.M. Sharaf,” Two control schemes to enhance the dynamic performance of the STATCOMand SSSC” IEEE Transaction Power Delivery, Vol. 20, no. 1, pp. 435-442, 2005.
- [21] D. Shen and P.W. Lehn, “ Modeling, analysis and control of a current source inverter-based STATCOM,” IEEE Transaction Power Delivery, Vol. 17, no. 1, pp. 248-253, 2002.
- [22] Y. Ye, M. Kazerani and V.H. Quintana,” Current source converter based STATCOM: Modeling and Control” IEEE Transaction Power Delivery, Vol. 20, no. 2, pp. 795-800, 2005.